

SPX SmartPilot System Installation Guide SPX 10, SPX 30, SPX Solenoid

Document reference: 87072-2
Date: November 2007

Contents

Chapter 1: Before you begin	1
1.1 Installation overview	1
Planning	1
Installation	1
1.2 Certified installation	2
1.3 Further assistance	2
www.raymarine.com	2
1.4 Product documents	3
Chapter 2: System overviews	5
2.1 The autopilot	5
2.2 Data systems	5
SeaTalkng	6
SeaTalk	11
NMEA 0183 / other manufacturers' equipment	15
2.3 Schematic diagram	16
Chapter 3: Installation	17
3.1 Autopilot system components	18
Parts supplied	18
Required additional components	20
Optional additional components	20
3.2 Cable connection points and fuses	20
3.3 Autopilot controller	24
3.4 Drive unit	25
Clutch	26
3.5 Power and drive cables	27
Circuit breaker and fuse information	28
Solenoid drives	30
3.6 Grounding the SPX SmartPilot	31
3.7 Connecting the data cables	31
3.8 Compass	37
3.9 Rudder reference	38
3.10 Sleep switch (optional)	39
3.11 External alarm (optional)	39
3.12 Wind vane (sail boats)	39
3.13 Test the system	40
Switch on	40
3.14 Final fix	40
Secure all cables	41
3.15 Commissioning	41
Chapter 4: SPX SmartPilot specifications	43
Chapter 5: NMEA 0183 sentences	45

Preface

Warnings and cautions



WARNING: Product installation & operation

This equipment must be installed, commissioned and operated in accordance with the Raymarine instructions provided. Failure to do so could result in personal injury, damage to your boat and/or poor product performance. Before you install the SPX SmartPilot system, check that individual components are the correct voltage for your boat's supply.

CAUTION: As correct performance of the boat's steering is critical for safety, we **STRONGLY RECOMMEND** that an Authorized Raymarine Service Representative fits this product. You will only receive full warranty benefits if you can show that an Authorized Raymarine Service Representative has installed and commissioned this product.



WARNING: Electrical safety

Make sure you have switched off the power supply before you start installing this product.



WARNING: Navigational safety

Although we have designed this product to be accurate and reliable, many factors can affect its performance. Therefore, it should serve only as an aid to navigation and should never replace commonsense and navigational judgement. Always maintain a permanent watch so you can respond to situations as they develop.

Electromagnetic Compatibility (EMC) conformance

Raymarine equipment and accessories conform to the appropriate Electromagnetic Compatibility (EMC) regulations for use in the recreational marine environment. Correct installation is required to ensure that EMC performance is not compromised.

Always check the installation before going to sea to make sure that it is not affected by radio transmissions, engine starting or other forms of interference.

To do this:

1. Turn on all transmitting equipment (radar, VHF radio, etc).
2. Check that all electronic systems are unaffected by interference from the transmitting equipment.

EMC installation guidelines

Raymarine equipment and accessories conform to the appropriate Electromagnetic Compatibility (EMC) regulations. This minimizes electromagnetic interference between equipment, which could otherwise affect the performance of your system.

Correct installation is required to ensure that EMC performance is not compromised.

For **optimum** EMC performance, we make the following recommendations:

- Place Raymarine equipment and cables at least 3 ft (1 m) from any equipment that transmits, or cables that carry, radio signals from VHF radios, cables and antennas. In the case of SSB radios, the distance should be increased to 7 ft. (2 m).
- Place Raymarine equipment and cables more than 7 ft (2 m) from the path of a radar beam. A radar beam can normally be assumed to spread 20 degrees above and below the radiating element.
- Use a power source separate from that used for engine-start. This is important to prevent erratic behavior and data loss which can occur if the engine-start does not have a separate battery.
- Use Raymarine-specified cables.
- Do not cut or extend cables unless doing so is detailed in the installation manual.

Remember

Where constraints on the installation prevent any of the above recommendations:

- Always allow the maximum separation possible between different items of electrical equipment.

This will provide the best conditions for good EMC performance of the installation.

Suppression ferrites

Raymarine cables may be fitted with suppression ferrites. These are necessary for correct EMC performance. Any ferrite removed during installation must be replaced as soon as installation is complete.

Use only ferrites of the correct type, supplied by Raymarine authorized dealers.

Connections to other equipment

If Raymarine equipment is to be connected to other equipment using a cable not supplied by Raymarine, a Raymarine suppression ferrite **MUST** always be attached to the cable near the Raymarine unit.

General cabling guidelines

- Do not mix AC and DC cables.
- Adhere to EMC guidelines (above).
- Use Copex conduit where appropriate to protect cables.
- Label all cables for easy identification.
- Keep fluxgate compass cable separate from other cables.

EMC Servicing and maintenance

- Undue noise and interference may be a symptom of an EMC-related problem. Please report any EMC-related problem to your nearest Raymarine dealer. We use such information to improve our quality standards.
- To minimize any EMC related problems and ensure the best possible performance from your Raymarine equipment, follow the guidelines given in the installation instructions.

Product disposal



Waste Electrical and Electronic (WEEE) Directive

The WEEE Directive requires the recycling of waste electrical and electronic equipment.

Whilst the WEEE Directive does not apply to some of Raymarine's products, we support its policy and ask you to be aware of how to dispose of this product.

The crossed out wheeled bin symbol, illustrated above, and found on our products signifies that this product should not be disposed of in general waste or landfill.

Please contact your local dealer, national distributor or Raymarine Technical Services for information on product disposal.

Chapter 1: Before you begin

To achieve a safe and reliable installation of your SPX SmartPilot system, installation and commissioning must be carried out by a competent professional who should adhere to the instructions in this guide.

1.1 Installation overview

There are two key stages to successful installation of your SPX SmartPilot System: **planning** and **installation**.

Planning

Careful planning will ensure the autopilot system is correctly configured and connected in conjunction with your vessel's wider electronics system. To help you plan, read through the whole of this guide before beginning to install your SPX SmartPilot system. The key steps to the planning process are as follows:

- Plan system configuration and where to locate components (See *System overviews* on page 5).
- Plan cabling and connections (See *Cable connection points and fuses* on page 20, *Power and drive cables* on page 27 and *Data systems* on page 5).
- Produce a schematic diagram (See *Schematic diagram* on page 16).
- Ensure you have the right components (See *Autopilot system components* on page 18).

Installation

When you have planned your system, work through the following installation tasks in order, referring to the appropriate section of this guide and your schematic diagram.

1. Mount SPX SmartPilot. (See *To mount the SPX SmartPilot* on page 22)
2. Mount autopilot controller. (See *To mount the autopilot controller* on page 24)
3. Install drive unit. (See *To mount the drive unit* on page 26)
4. Route power cables. (See *Power and drive cables* on page 27)
5. Install ground. (See *To install ground* on page 31)
6. Connect data cables. (See *Connecting the data cables* on page 31)
7. Connect NMEA 0183 equipment if applicable. (See *To connect NMEA equipment* on page 36)
8. Mount compass. (See *To mount the compass* on page 37)
9. Mount rudder reference (if applicable). (See *To mount and connect the rudder reference (if applicable)* on page 38)
10. Install sleep switch (if applicable). (See *Sleep switch (optional)* on page 39)
11. Install external alarm (if applicable). (See *External alarm (optional)* on page 39)
12. Install wind vane (if applicable). (See *Wind vane (sail boats)* on page 39)
13. Connect cables to SPX SmartPilot. (See *Cable connection points and fuses* on page 20)
14. Final fix: secure all equipment in place; secure all cables. (See *Final fix* on page 40)

Note: *You should refer to the above checklists as you go through the installation process.*

1.2 Certified installation

Raymarine recommends certified installation by a Raymarine approved installer. A certified installation qualifies for enhanced warranty benefits. (See the separate warranty card packed with your product). For more information on certified installation contact your Raymarine dealer or refer to the Raymarine web site: www.raymarine.com.

1.3 Further assistance

Comprehensive customer support is available online and by telephone.

www.raymarine.com

In the Customer Service area you will find:

- Frequently Asked Questions (FAQs).
- Servicing information.
- Email access to the Raymarine Technical Support Department.
- Details of Raymarine agents worldwide.

Telephone helpline

In the USA

+1 603 881 5200 extension 2444

In the UK, Europe, the Middle East or the Far East

+44 (0) 23 9271 4713 (voice)

+44 (0) 23 9266 1228 (fax)

Help us to help you

When requesting service, please quote as much of the following product information as possible:

- Product type
- Model number
- Serial number
- Software issue number

1.4 Product documents

The following documents are available from www.raymarine.com/handbooks to help you install and operate an autopilot system based around the SPX SmartPilot:

Document	Part number
SPX System Installation Guide (this document). Professional installers should use this guide to ensure safe and effective set up of an SPX SmartPilot system.	87072-1
SPX System Commissioning Instructions. Following installation, this document, which is supplied with your autopilot controller, must be used to commission your autopilot system before it can be used safely.	81287-1
SeaTalkⁿ⁹ Reference Manual. This provides detailed information regarding SeaTalk ⁿ⁹ connectivity.	81300-1
SPX service / repair manual	
Autopilot Operating Guide. Supplied with the ST70 autopilot controller.	81289-1
Product installation guides. Separate installation sheets are provided with individual components of the autopilot system including the compass, rudder reference sensor, controller and drive	

To the best of our knowledge, the information in the product documents was correct when they went to press. However, Raymarine cannot accept liability for any inaccuracies or omissions in product documents.

In addition, our policy of continuous product improvement may change specifications without notice. Therefore, Raymarine cannot accept liability for any differences between the product and the accompanying documents.

Chapter 2: System overviews

This section contains overview information on different types of data system and how the autopilot fits into each.

2.1 The autopilot

The autopilot consists of:

- SPX SmartPilot course computer
- Autopilot controller
- Drive unit
- Fluxgate compass
- Rudder reference sensor (required in SPX Solenoid installations, optional with SPX 10 and SPX 30 installations)

These components are linked logically as shown below:

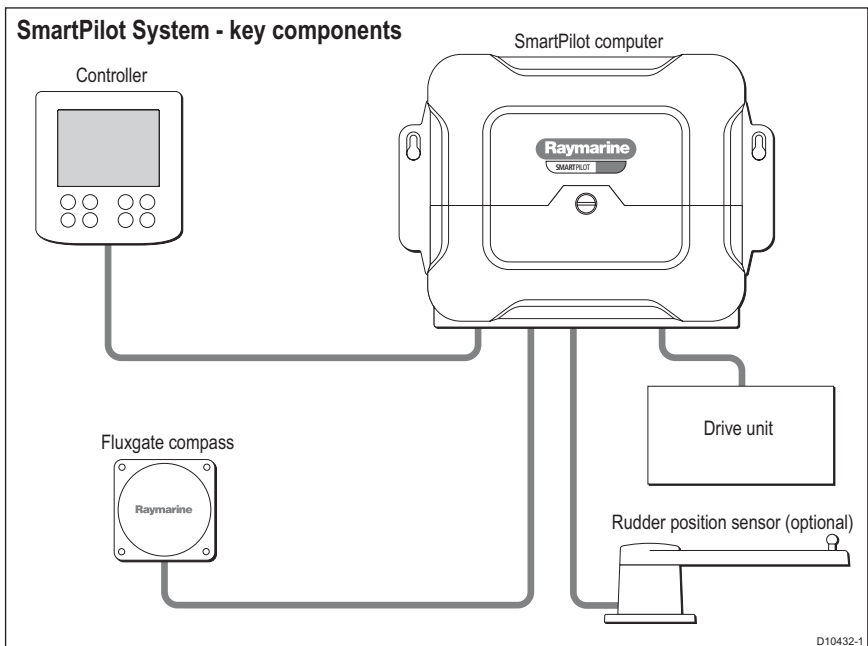

2.2 Data systems

Data cables carry data and power to the autopilot controller, instruments, and onboard electronics such as GPS or chartplotter. The SPX SmartPilot can use information from other equipment on the data system to enhance course keeping and provide additional features. Most Raymarine products can be connected directly to Raymarine's proprietary data systems, SeaTalk^{ng} or SeaTalk. NMEA 0183 cables

may be required if you are connecting NMEA 0183 equipment such as compass, GPS or chartplotter.

SeaTalk^{ng}

The diagram below shows how the SPX unit fits into a typical SeaTalk^{ng} data system with instruments and transducers.

Typical Seataalk^{ng} system with autopilot

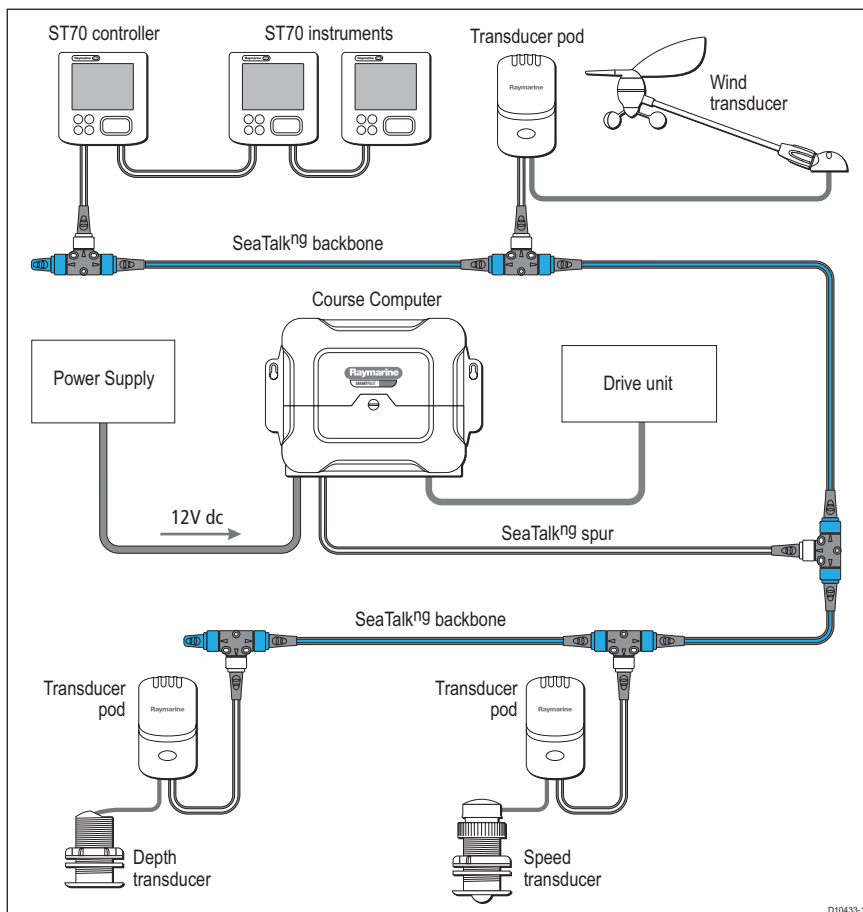

Note: SeaTalk^{ng} system structures and load limitations: There are restrictions on cable lengths, power location and the number of components you may connect to a SeaTalk^{ng} system. For complete information on SeaTalk^{ng} connectivity, refer to the **SeaTalk^{ng} Installation Guide** supplied with the SeaTalk^{ng} Backbone Kit.



In a SeaTalk^{ng} system, components are connected to the SeaTalk^{ng} backbone cable using spur cables.

- Spur cables should be kept short to keep components as close to the backbone as possible.
- The ST70 autopilot controller is supplied with a 400mm spur cable, which may be extended if necessary. However, it is preferable to extend the backbone so the connection point is within 400mm of the location of the controller.
- The SPX SmartPilot is connected to the backbone using a plug-in cable (supplied).
- Instruments can be connected via spur cables or daisy-chained together on a bus.
- The SeaTalk^{ng} backbone cable is available as part of a standard kit.

Optional cabling and connectors

For additional components and cables go to www.raymarine.com where you can either source products from our online store or find your nearest Raymarine distributor or service dealer.

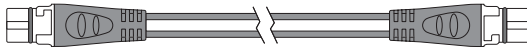
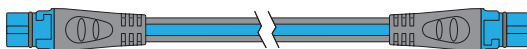
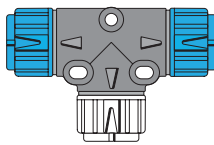
SeaTalk^{ng} example cabling options

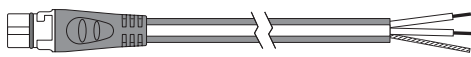
<p>Spur cable</p> 	<p>Part number</p> <p>A06038 - 1 ft 3 in (400 mm) A06039 - 3 ft 3 in (1 m) A06040 - 9 ft 10 in (3 m) A06041 - 16 ft 4 in (5 m)</p>
<p>Backbone kit</p> 	<p>A25062</p> <p>Backbone cable - 16 ft 4 in (5 m), (x 2) 65 ft 7 in (20 m)</p>
	<p>T piece, (x 4)</p>
	<p>Backbone terminator, (x 2)</p>
	<p>Power cable</p>

SeaTalk^{ng} system with single autopilot controller

The simplest type of SeaTalk^{ng} system has a single SeaTalk^{ng} bus including one controller and several instruments.

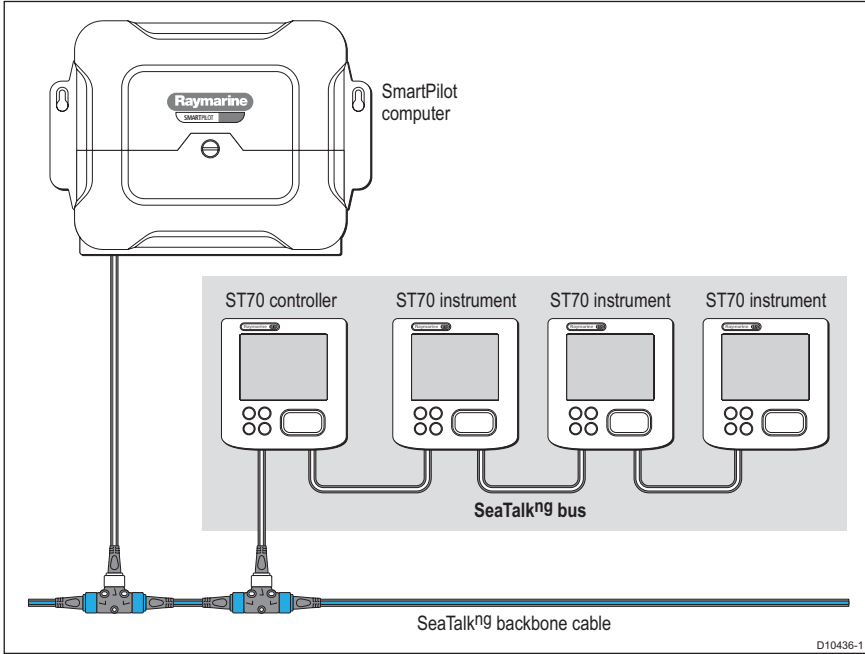

SeaTalk^{ng} system with second autopilot controller

You may add a second pilot controller, which repeats autopilot information. The second controller is also connected to the backbone using a spur cable.

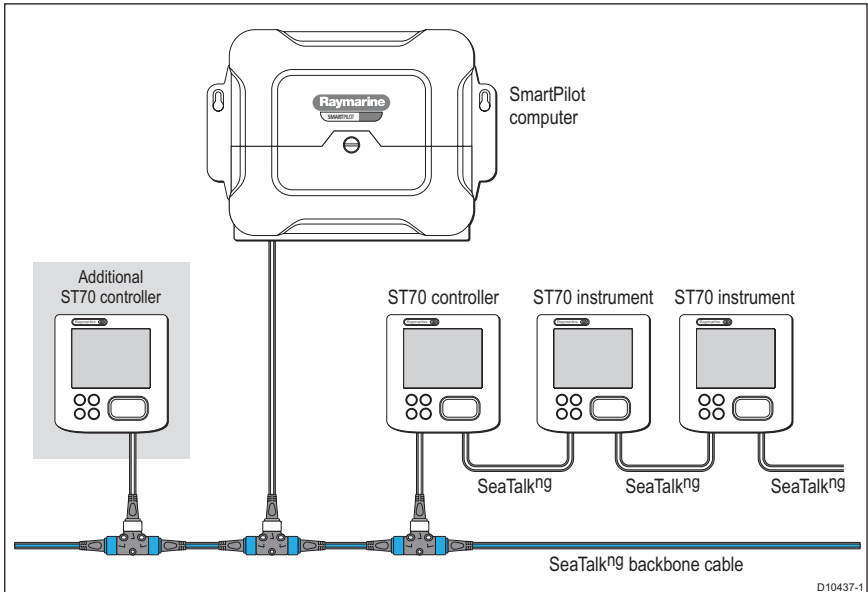

Powering SeaTalk^{ng}

The SPX SmartPilot normally provides power to the SeaTalk^{ng} system but you may decide to power the SeaTalk^{ng} system separately.

SeaTalk^{ng} system with separate power supply

In installations where the SeaTalk^{ng} backbone is powered separately, or, if you are running an NMEA 2000-compliant system, the SeaTalk^{ng} switch above the SeaTalk^{ng} terminal on the SPX SmartPilot must be moved to the OFF position

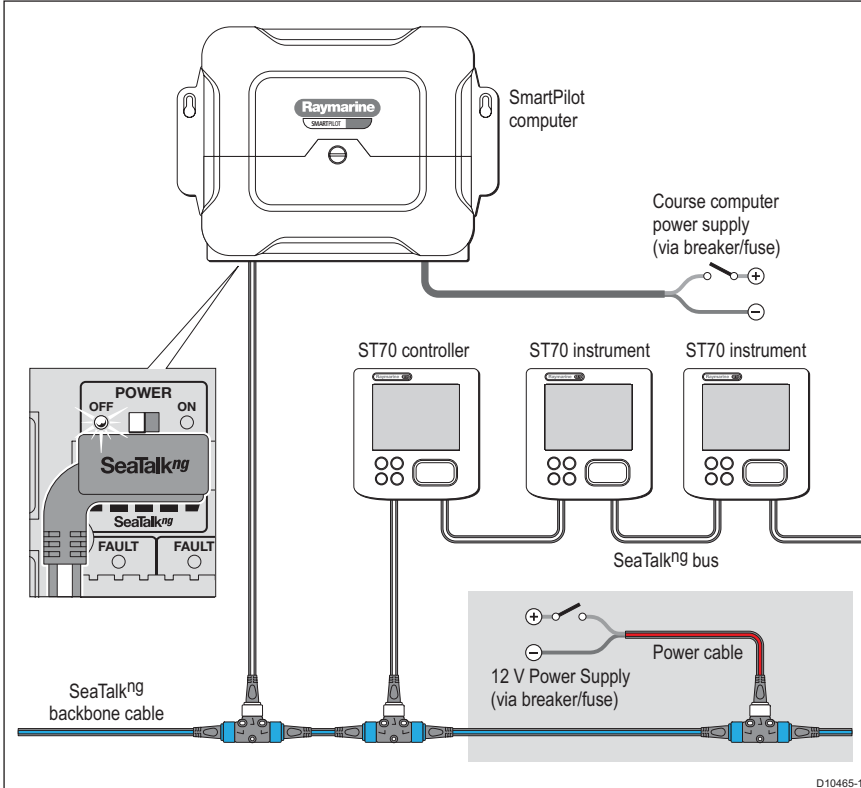

SeaTalk

The diagram below shows how the SPX unit fits into a SeaTalk data system with instruments and transducers.

Example SeaTalk system with autopilot

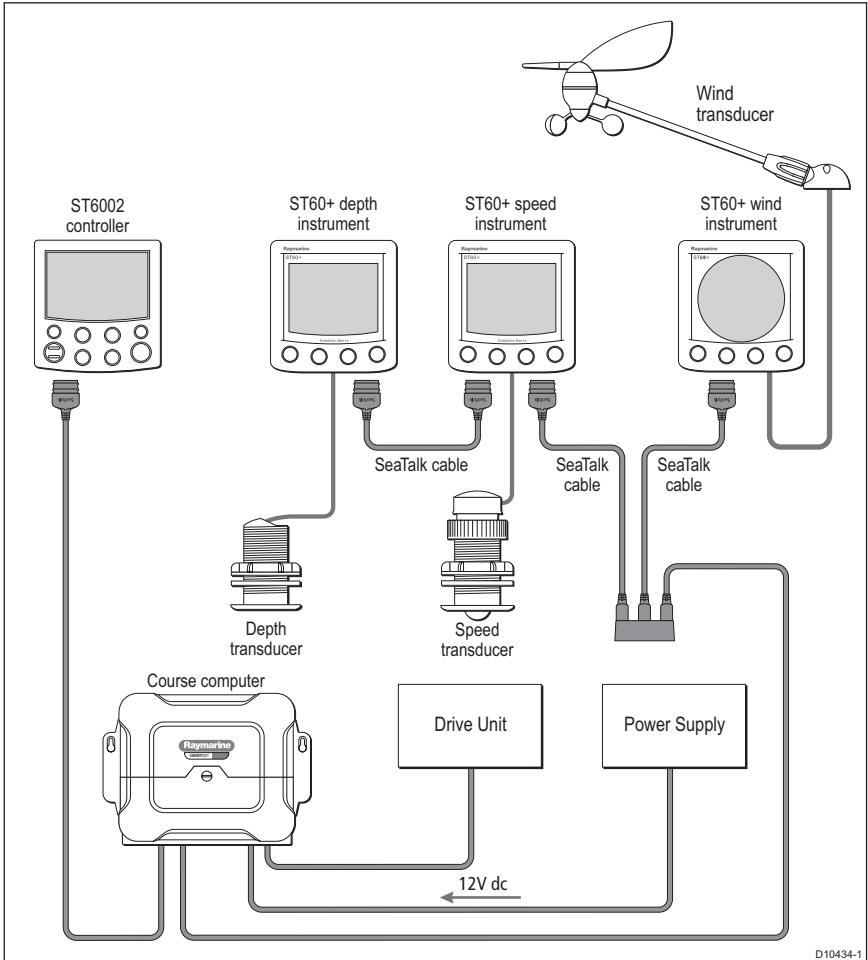

A SeaTalk based network does not have a central backbone cable. Connector blocks are used to connect different parts of the system.

Example SeaTalk cable

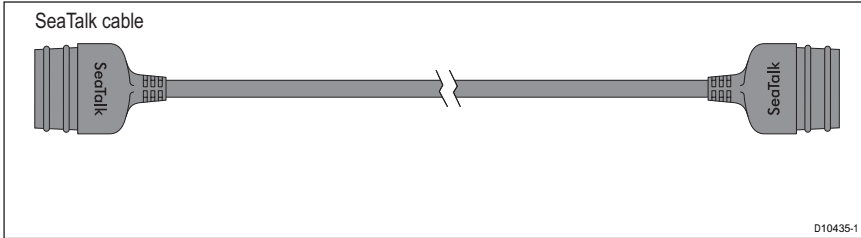

SeaTalk system with single autopilot controller

The simplest type of SeaTalk system has a single SeaTalk bus including one controller and several instruments.

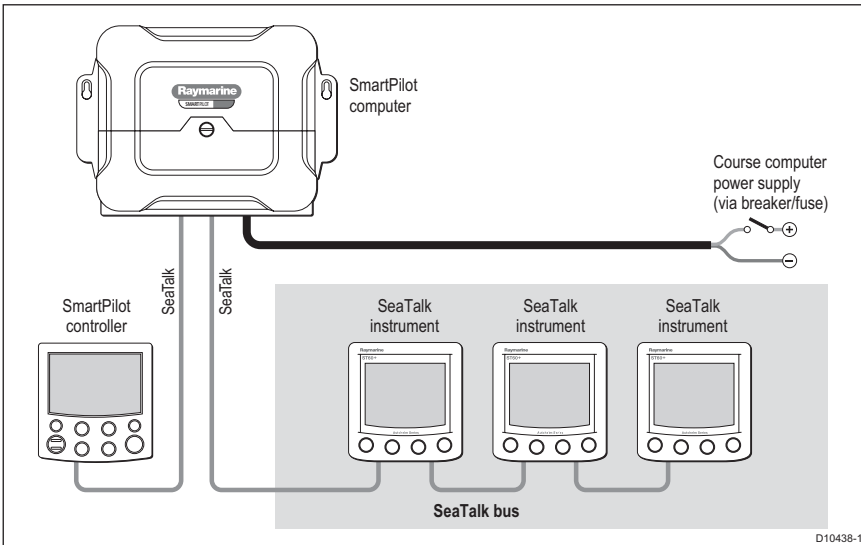

SeaTalk system with second autopilot controller

You may add a second controller to your system, which repeats autopilot information.

If you are using two control units, we recommend they are connected to separate SeaTalk terminals on the SPX SmartPilot.

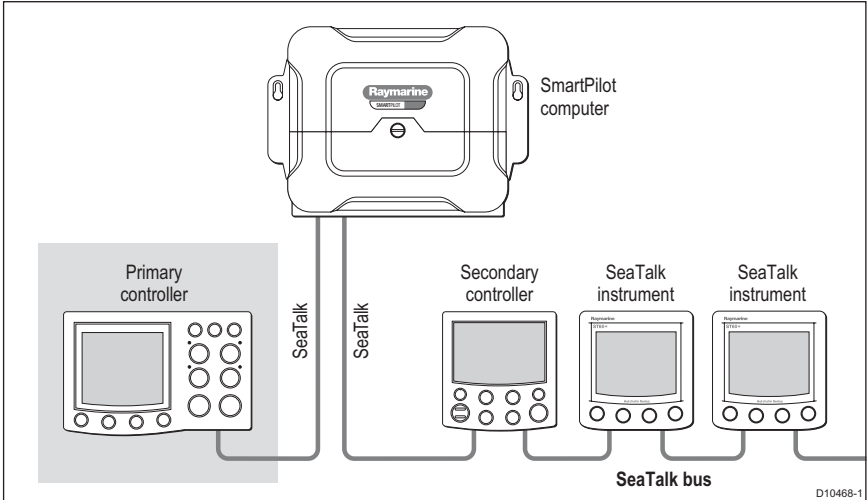

Powering SeaTalk

The SPX SmartPilot normally provides power to the SeaTalk system. However your system may require an additional or separate power supply.

Power supplied to both ends of the SeaTalk bus.

Depending on the number of components on the system and the total length of data cabling, it may be necessary to provide a 12 V power supply to each end of the data bus ('ring-main' style):

- Connect the SeaTalk bus as normal.
- Connect a second SeaTalk cable to the SmartPilot and route it to the far end of the SeaTalk bus.
- For the second cable, do NOT connect the SeaTalk YELLOW wire at the SPX SmartPilot **SEATALK** terminal.

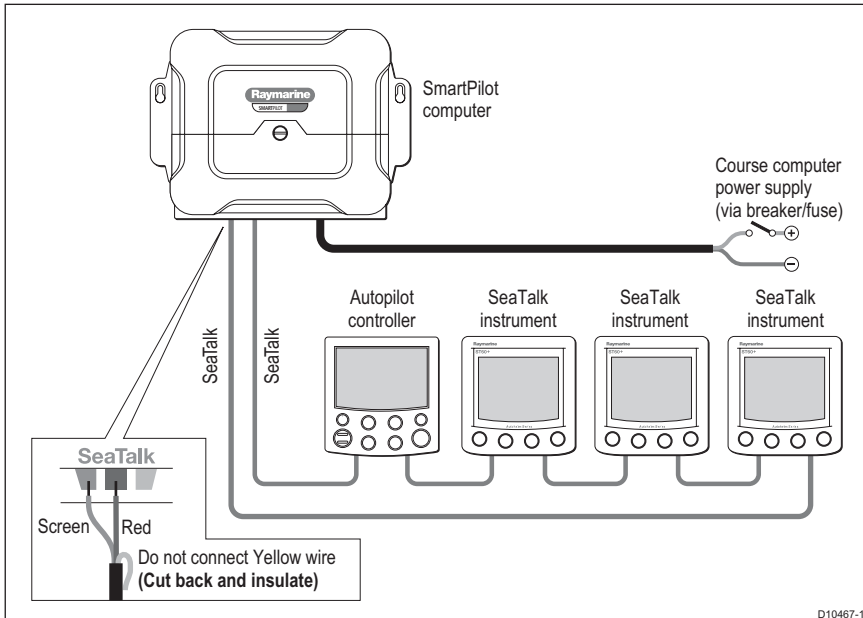

SeaTalk system with dedicated power supply

You can use a separate power supply to power the SeaTalk system if required. In this instance do **NOT** connect the SeaTalk RED wire at the SPX SmartPilot **SEATALK** terminal.

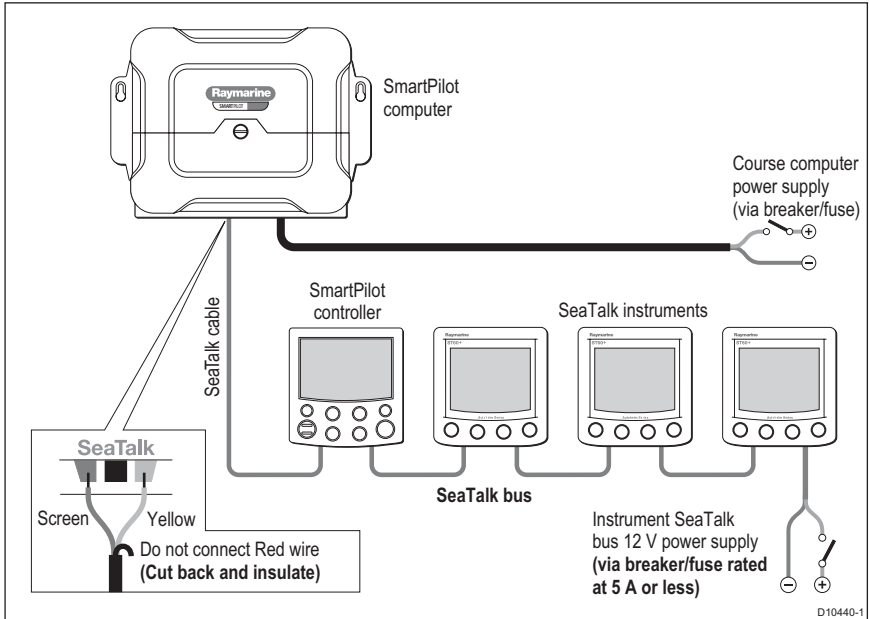

NMEA 0183 / other manufacturers' equipment

Most Raymarine equipment will connect to your data system via SeaTalk^{ng} or SeaTalk (except for A-series, which connects via NMEA 0183). Other manufacturers' equipment connects via NMEA cabling.

2.3 Schematic diagram

To help ensure an accurate and safe installation, produce a schematic diagram to work from. This drawing will also be useful for any future additions or maintenance of the system. The diagram should include:

- Location of all components. See *EMC installation guidelines* on page vi for conditions that may affect the location of specific components such as the compass.
- Connectors, cable types, routes and lengths.

When you have completed the schematic, you are ready to begin installing the SPX system.

Chapter 3: Installation

Before starting the installation procedure, ensure you have read *Chapter 2: System overviews* and are clear about the data system you are using and how components will be connected. You should have the following to hand:

- All components of the autopilot system and related equipment.
- The correct type and length of power and data cabling.
- Schematic diagram detailing autopilot system location and connections, including connections to existing equipment. Refer to this diagram at each step of the installation process.

You should also check that existing marine electronics, such as the GPS and chartplotter, are installed and working.



WARNING: Electrical safety

Before you make any electrical connections, ensure the power supply is switched off and you have read the EMC installation guidelines (see *page 2*)

WARNING: Install at dockside

For safety reasons your boat must be at dockside before commencing installation.

3.1 Autopilot system components

This section tells you what has been supplied as part of the SPX SmartPilot core pack, the additional or optional components you might need, and how to install them.

Parts supplied

The components supplied with your SPX SmartPilot core pack are shown below
SPX 10

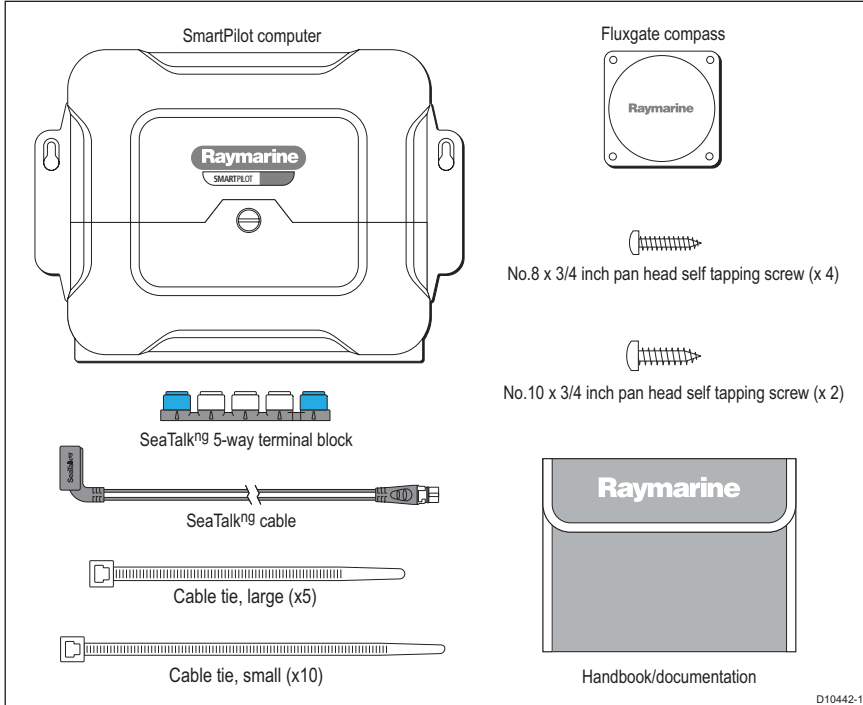

Note: *The SPX 10 is designed to operate without a rudder reference unit. In a small percentage of applications, such as extremely high performance power boats, you may find slightly enhanced performance with the addition of a rudder reference.*

SPX 30 and SPX Solenoid

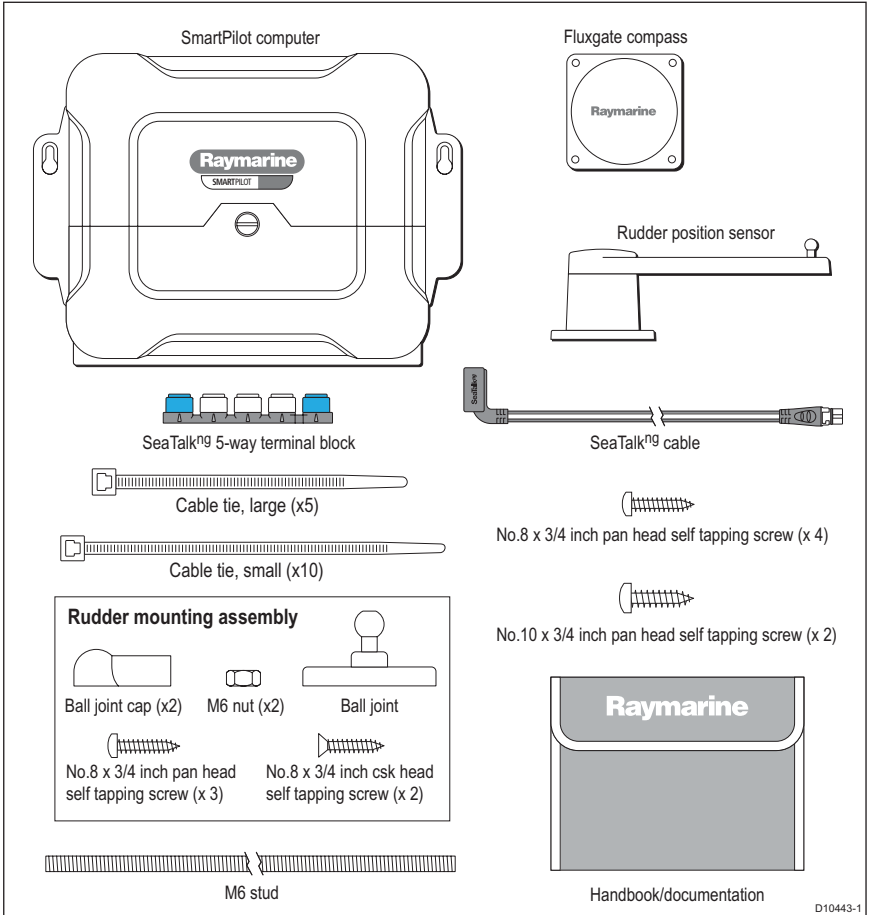

Required additional components

To complete your system, you will need the following components in addition to the SPX core pack.

- Autopilot controller (see *Autopilot controller* on page 24)
- Drive unit (See *Drive unit* on page 25)
- Power and drive cables (see *Power and drive cables* on page 27)

Optional additional components

- Rudder reference - **SPX 10 only** (see *Rudder reference* on page 38)
- Sleep switch (see *Sleep switch (optional)* on page 39)
- External alarm (see *External alarm (optional)* on page 39)
- Wind vane (See *Wind vane (sail boats)* on page 39)

3.2 Cable connection points and fuses

Cable connection points on the SPX 10, SPX 30 and SPX Solenoid vary slightly.

Throughout the following sets of instructions, refer to the diagrams below to see the location of the various connections you will be using.

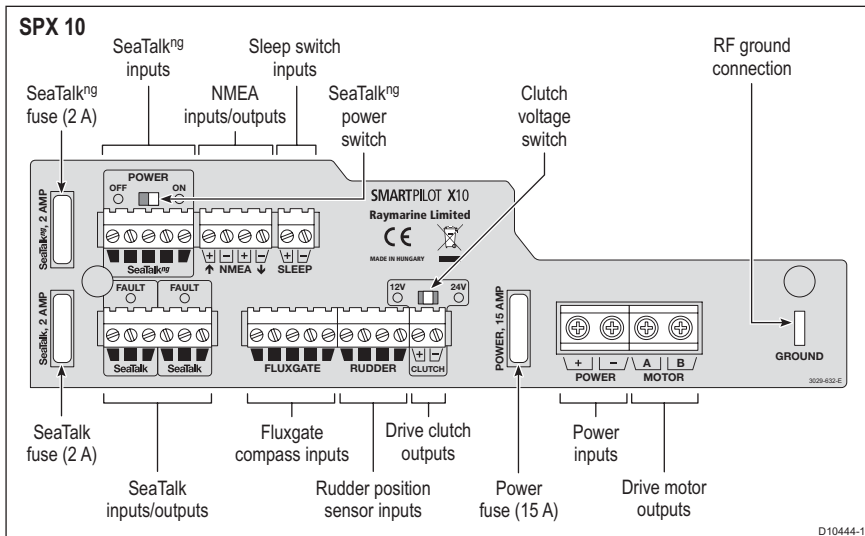

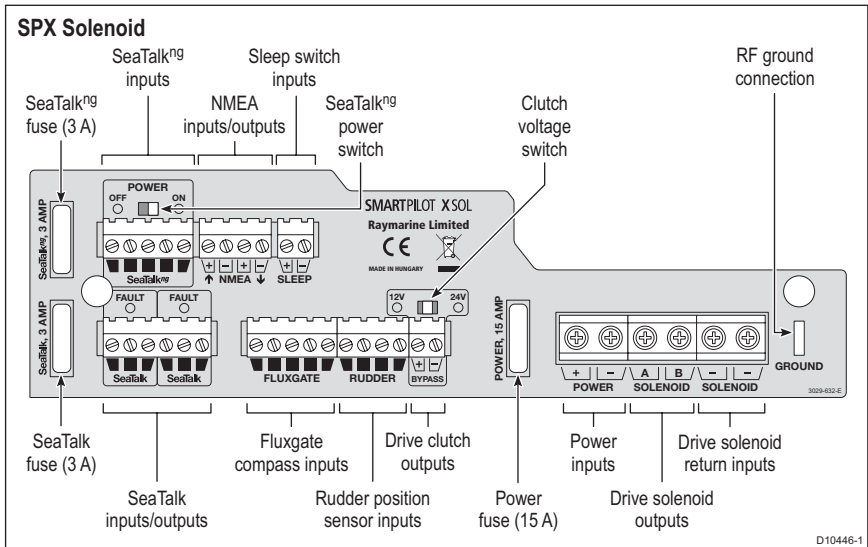
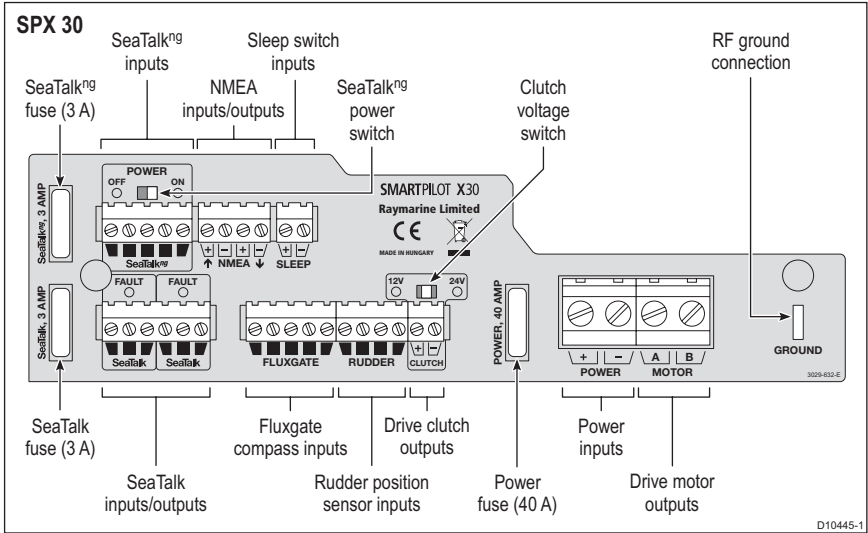

Fuse protection

The **POWER**, **SEATALK^{NG}** and **SEATALK** terminals are fuse protected against short-circuits and misconnections (see *SPX SmartPilot specifications on page 43*). In these situations the fuse will trip and reset automatically when the problem is rectified. Spare standard automotive blade fuses are supplied with your SPX SmartPilot and are easily available. Your Raymarine dealer can also provide a replacement fuse pack.

To mount the SPX SmartPilot

Fasten the SPX securely to a vertical surface below decks, away from the engine, where it will be protected from moisture and knocks.

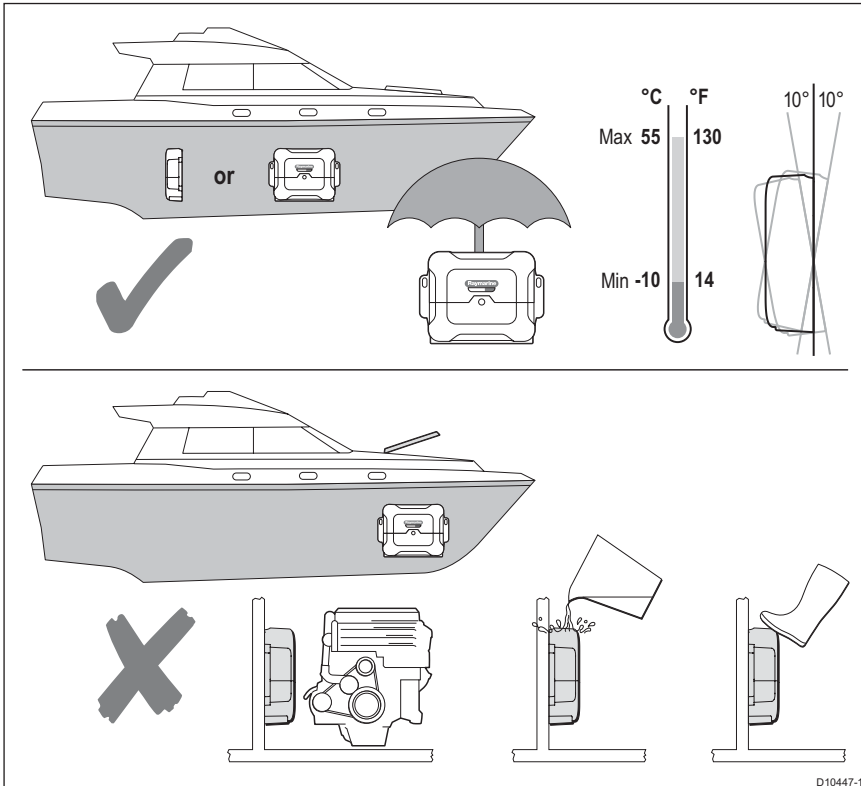

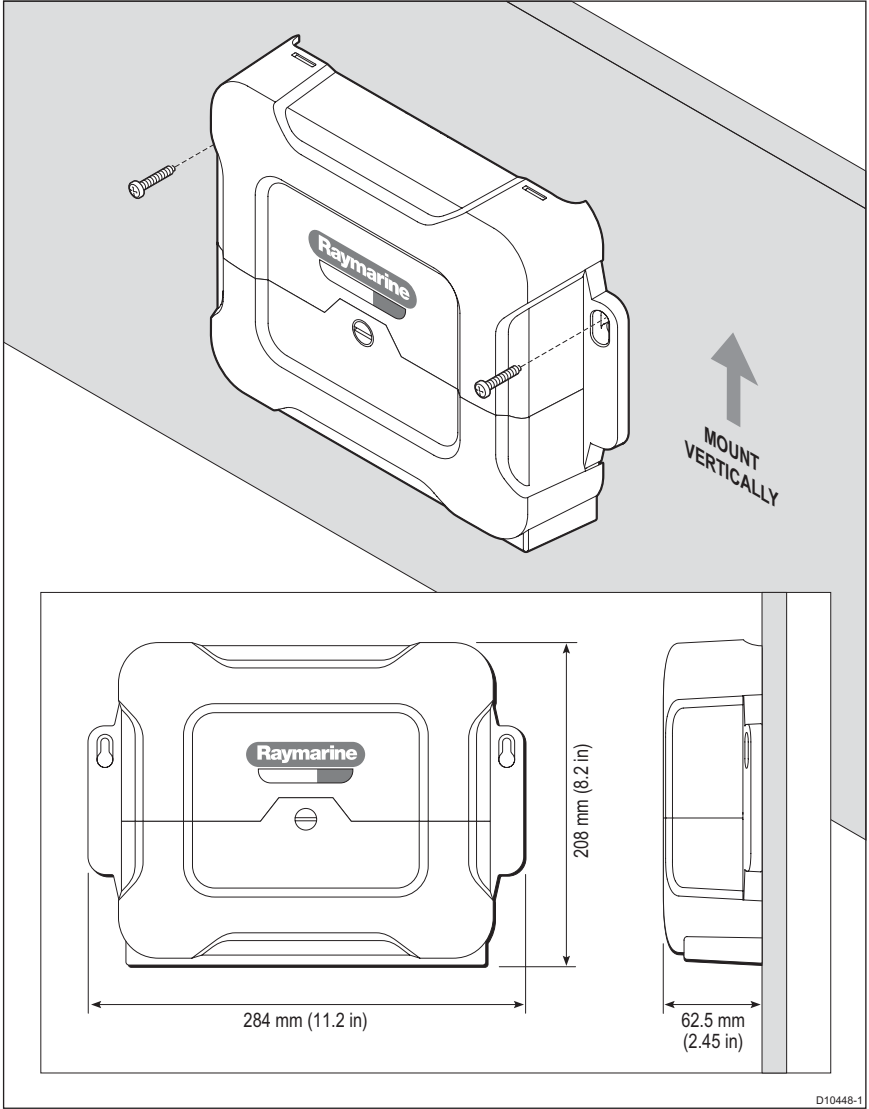

Removing and replacing the connector cover

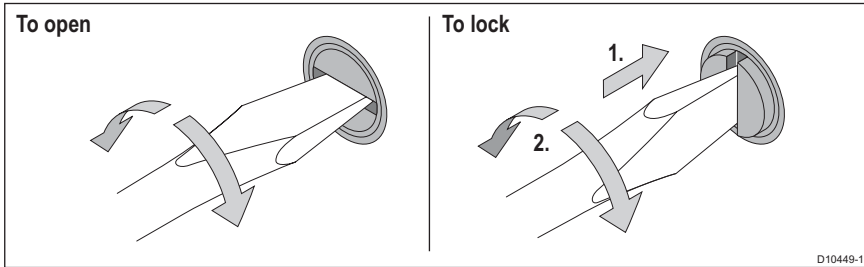

3.3 Autopilot controller

- Raymarine autopilot controllers ST70 autopilot controller, ST6002, ST7002, ST8002, S100 and Smart Controller are compatible with the SPX SmartPilot

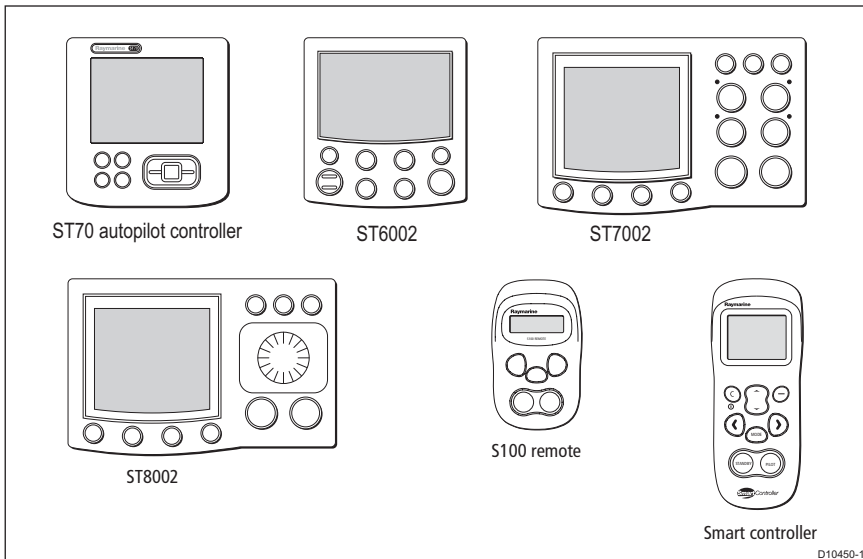

To mount the autopilot controller

- Follow the installation instructions supplied with the autopilot controller.
- Do not secure tightly until the data cables are connected and the system has been tested.

3.4 Drive unit

Various types of drive unit are available to match to your steering system:

- *Hydraulic pump - used to connect to hydraulic steering systems*
- *Mechanical linear - used in sailing vessels, the mechanical linear drive moves the rudder directly by pushing the tiller arm or a rudder quadrant.*
- *Mechanical rotary - designed for power and sailboat systems that can be driven from the helm position through a chain and sprocket e.g. cable and rod.*

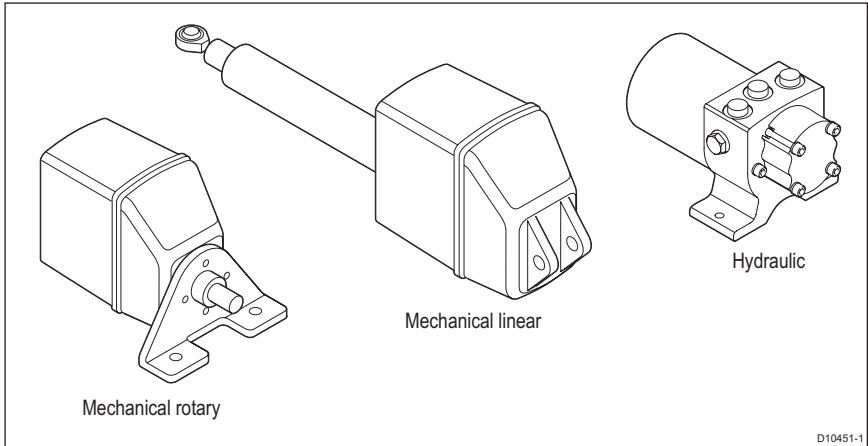

Refer to the following table for drive unit compatibility with the SPX SmartPilot.

SPX SmartPilot	Supply voltage	Drive unit compatibility
SPX 10	12 V or 24V	All Raymarine Type-1 12 V or 24 V drives and pumps. Drive voltage must be matched to boat's supply voltage.
SPX 30	12 V or 24 V	All Raymarine Type-1, Type-2 and Type-3 12 V and 24 V drives and pumps. Drive voltage must be matched to boat's supply voltage.
SPX SOLENOID	12 V or 24 V	All solenoid drives: Raymarine constant-running pump or similar.

Clutch

Raymarine drives

Raymarine drives have a 12 V clutch. The clutch switch default setting on the SPX SmartPilot is 12 V.

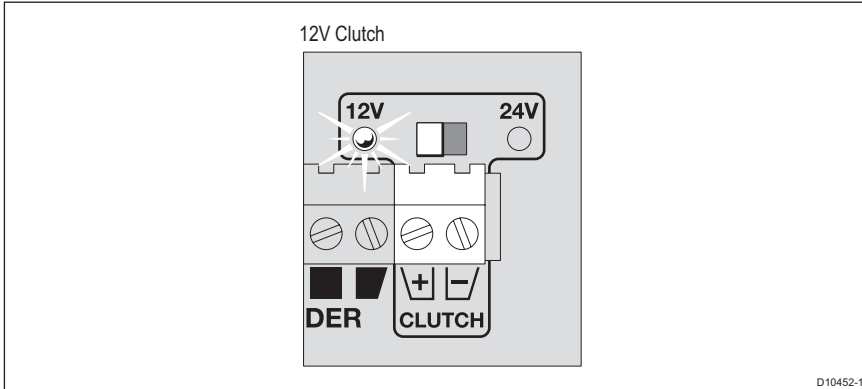

Non-Raymarine drives

- SPX SmartPilots are compatible with other manufacturers' drives, which have either 12 V or 24 V clutches.

CAUTION: If the drive unit has a 24 V clutch, move the clutch fuse switch on the SPX SmartPilot to the right. Do not confuse the operating voltage of the clutch with the voltage used on the boat.

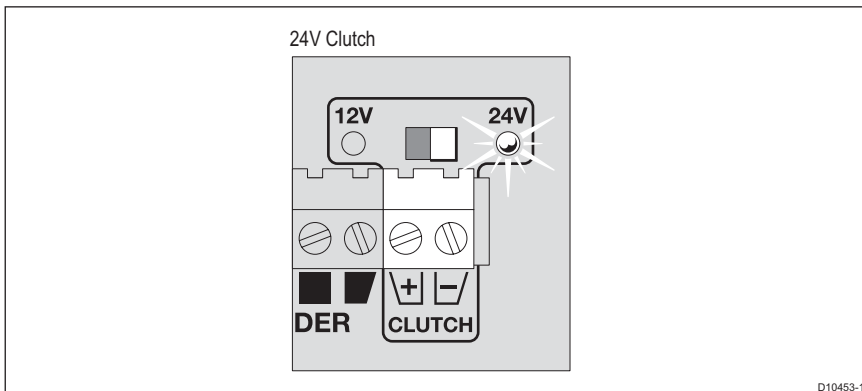

To mount the drive unit

- Fit the drive unit (hydraulic, mechanical or solenoid) to the steering system, following the installation instructions supplied with the drive.

Note: You will need to power the drive unit with a cable routed from the SPX SmartPilot (see *Power and drive cables* on page 27).

3.5 Power and drive cables

CAUTION: The SPX SmartPilot must have a dedicated power source. Do NOT attempt to provide power to the SPX SmartPilot through SeaTalk or SeaTalk^{ng}.

Power is routed from the vessel's electrical distribution panel to the drive unit through the SPX SmartPilot.

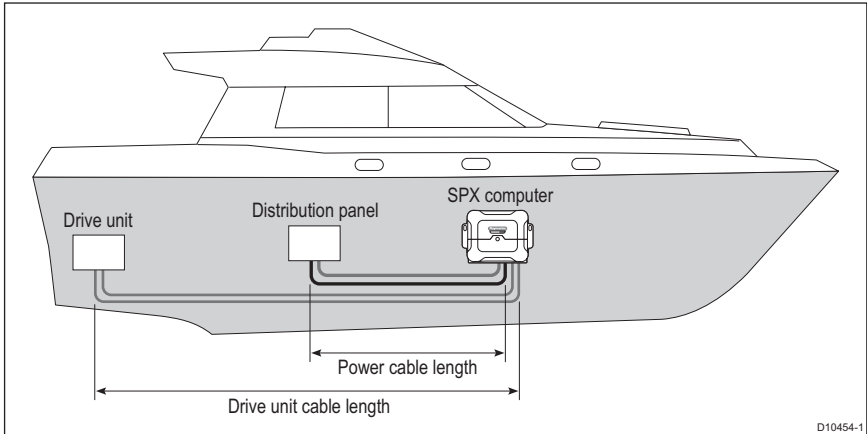

D10454-1

CAUTION: Use of incorrect power cable size could cause your SmartPilot to malfunction and will reduce the power supplied to the drive unit. Ensure the correct size is used and, if in doubt, use a heavier gauge cable.

You need to supply two lengths of power cable:

1. Distribution panel to SPX SmartPilot.
2. SPX SmartPilot to drive unit.

Select the appropriate type of power cable for each length using the table below as a guide.

Drive type	Cable length	Cable gauge	Copper area
Type 1 drive 12/24 V (I/O drive) (X 10) CR pump solenoids (X SOL)	up to 7m (10ft)	14 AWG	2.5 mm ²
	up to 10m (16ft)	12 AWG	4 mm ²
Type 2 drive 12 V (X 30)	up to 5m (16ft)	10 AWG	6 mm ²
	up to 7m (23ft)	8 AWG	10 mm ²
Type 2 drive 24 V (X30)	up to 3m (10ft)	12 AWG	4 mm ²
	up to 5m (16ft)	10 AWG	6 mm ²
	up to 10m (32ft)	8 AWG	10 mm ²

Drive type	Cable length	Cable gauge	Copper area
Type 3 drive 12 V (X30)	up to 5m (16ft)	8 AWG	10 mm ²
Type 3 drive 24 V (X30)	up to 5m (16ft)	10 AWG	6 mm ²
	up to 7m (23ft)	8 AWG	10 mm ²

Circuit breaker and fuse information

Select the appropriate circuit breaker or fuse for your system using the table below as a guide.

Drive unit	Fuse	Thermal over-current circuit breaker
Rotary drive	Type 1, 12 V	25 A
Linear drive	Type 1, 24 V	25 A
Hydraulic pump	Type 2, 12 V	40 A
Hydraulic linear	Type 2, 24 V	30 A
	Type 3, 12V and 24V	40 A
I/O	15 A	10 A
CR pump solenoids	10 A	10 A

To connect the power and drive unit

- Fit the power cable to the distribution panel. (We recommend using a dedicated circuit breaker for the power cable).
- Route the power cable to the SPX SmartPilot and fit it to the **POWER INPUTS** terminal.
- Connect the drive cables to the **DRIVE MOTOR OUTPUTS** terminal.
- Connect the drive to the **DRIVE CLUTCH OUTPUTS**.

Motor phasing is determined during commissioning: refer to separate commissioning guide for further information.

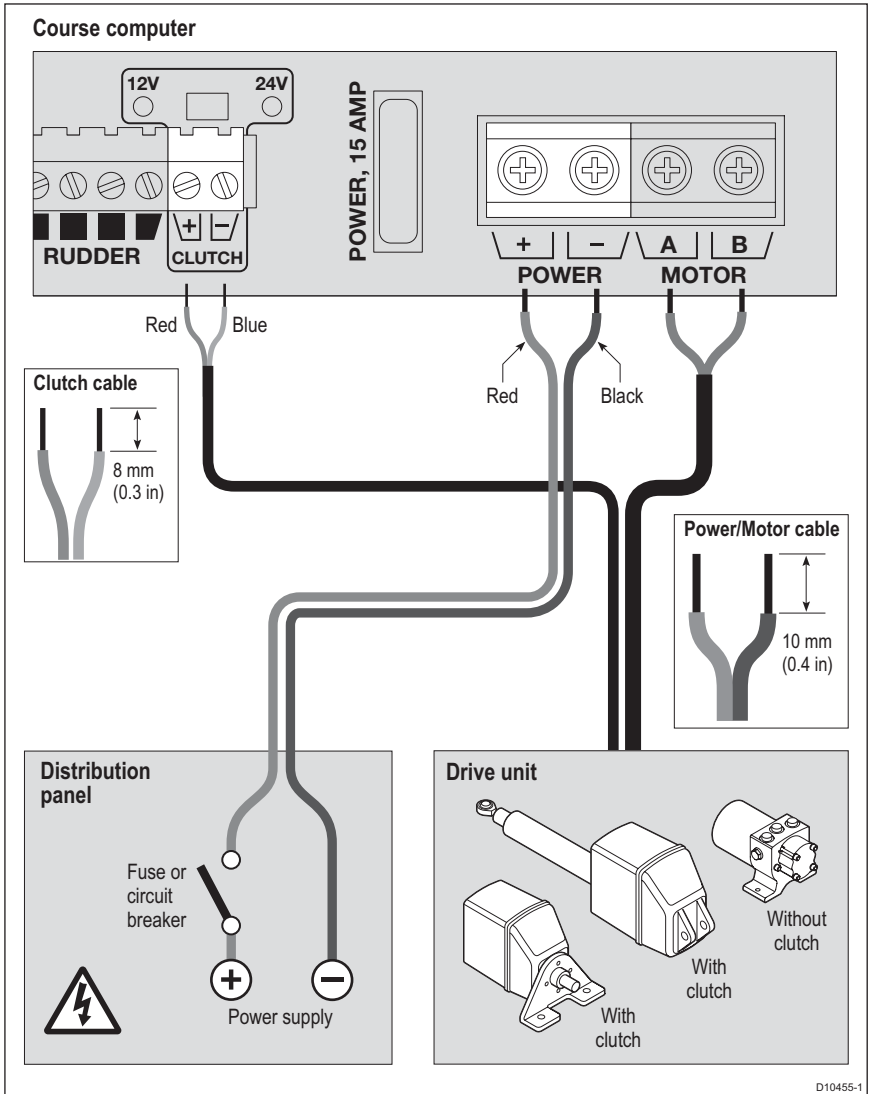

Solenoid drives

- If you are using a solenoid drive, connect the drive cables to the **MOTOR** and **SOLENOID** terminals on the SPX SmartPilot.

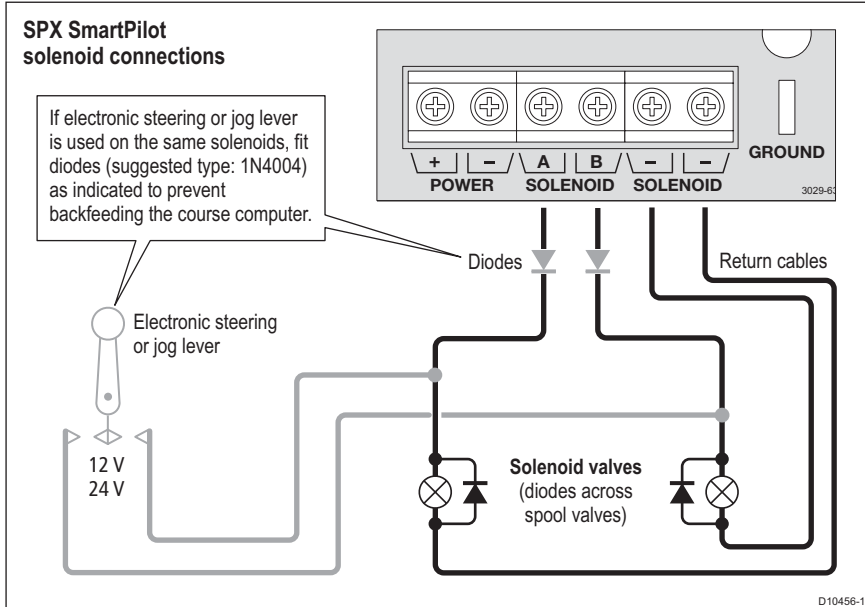

3.6 Grounding the SPX SmartPilot

CAUTION: SPX systems **MUST** be connected to ship's ground. Failure to connect the unit to ground may cause it, or other on-board electronics to function incorrectly.

- Use a dedicated earthing plate (e.g. dynaplate) in contact with the water.
- Use flat tinned copper braid, 30 A rating (1/4 inch) or greater. Equivalent stranded wire diameter 4mm or greater.
- Keep the length of the earth braid as short as possible.

To install ground

- Using the supplied yellow (1/4 inch) female spade connector, connect the earthing braid to the **RF GND** terminal on the SPX SmartPilot.
- Connect the other end of the earth strap to a dedicated earthing plate in contact with the water.

Note: *If it is not possible to connect to a dedicated earthing plate, the earth braid may be connected to the negative pole of the battery (ideally at the battery itself).*

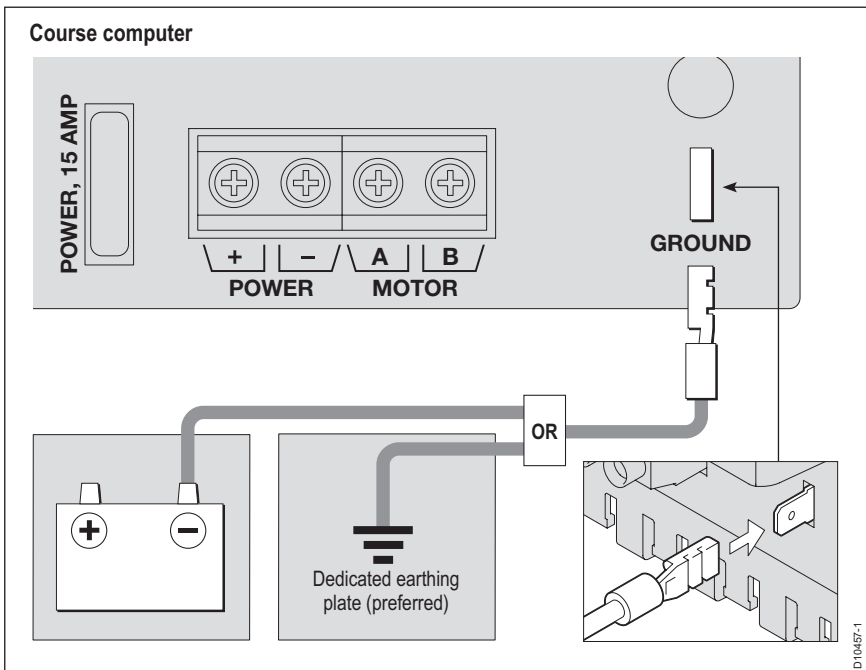

3.7 Connecting the data cables

For overview information on SeaTalk and SeaTalk^{ng}, and the different types of cabling and connections used by each, see *Data systems* on page 5.

To connect SeaTalk^{ng} cabling

WARNING: Use correct fuse

The fuse supplying the SeaTalk^{ng} system MUST be rated at 5A or less.

SPX SmartPilot

- Connect the SeaTalk^{ng} cable, supplied with the SPX core pack, to the SeaTalk^{ng} terminal on the SPX.

Note: In installations where the SeaTalk^{ng} backbone is powered separately, or if you are running an NMEA 2000-compliant system, the SeaTalk^{ng} switch above the SeaTalk^{ng} terminal on the SPX SmartPilot should be moved to the OFF position. Refer to **SeaTalk^{ng} Reference Manual** for more information on connectivity, including connection to NMEA equipment.

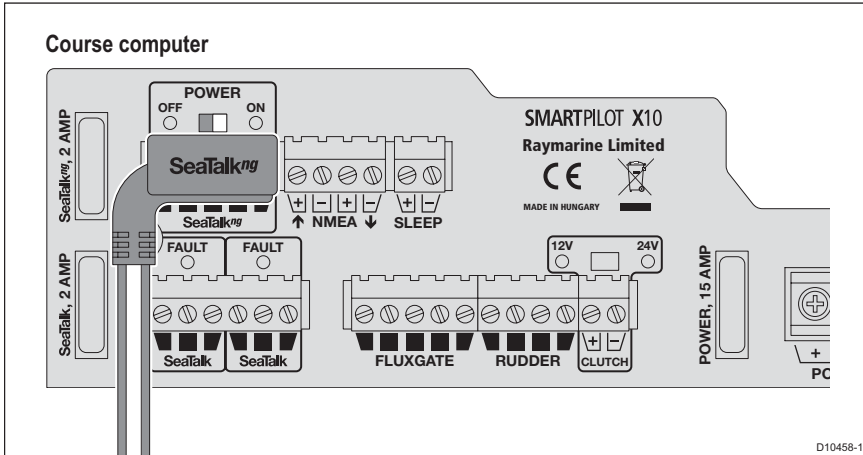

- Connect the other end of the SeaTalk^{ng} cable into a T-piece connector on the SeaTalk^{ng} backbone cable or to a 3- or 5-way connector block.

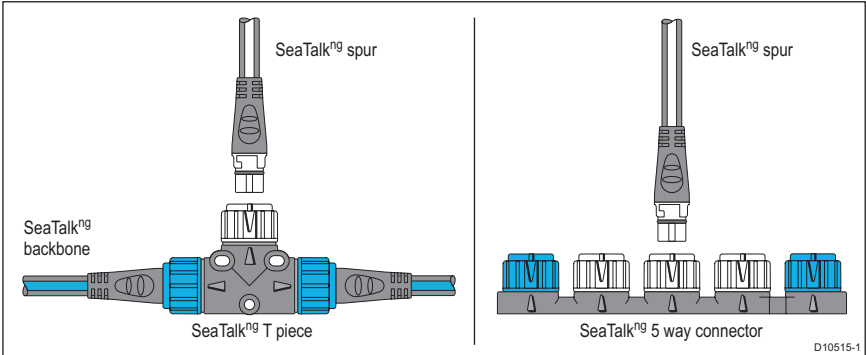

Autopilot controller

- Connect the autopilot controller to the SeaTalk^{ng} backbone cable or to an instrument. (For detailed information refer to your autopilot controller installation guide and the SeaTalk^{ng} Reference Manual).

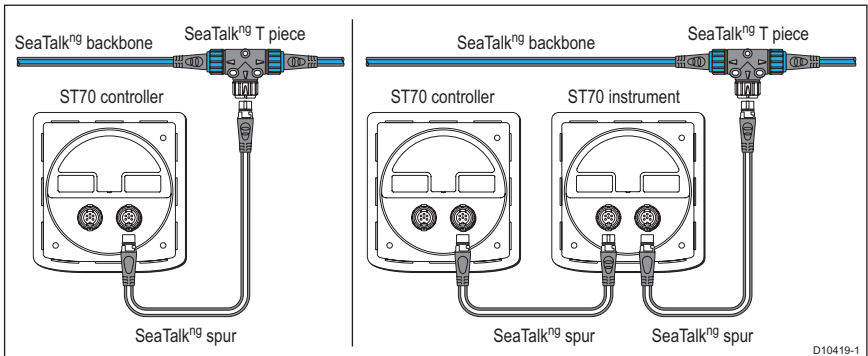

To connect SeaTalk cabling

WARNING: Use correct fuse

The fuse supplying the SeaTalk system MUST be rated at 5A or less.

SPX SmartPilot

- Connect SeaTalk cable to **SEATALK** terminal.
- Connect the other end of the SeaTalk cable to a 3-way terminal block or other suitable connector on the system.

Note: If you are supplying power separately to the SeaTalk bus, do NOT connect the red wire at the SPX SmartPilot.

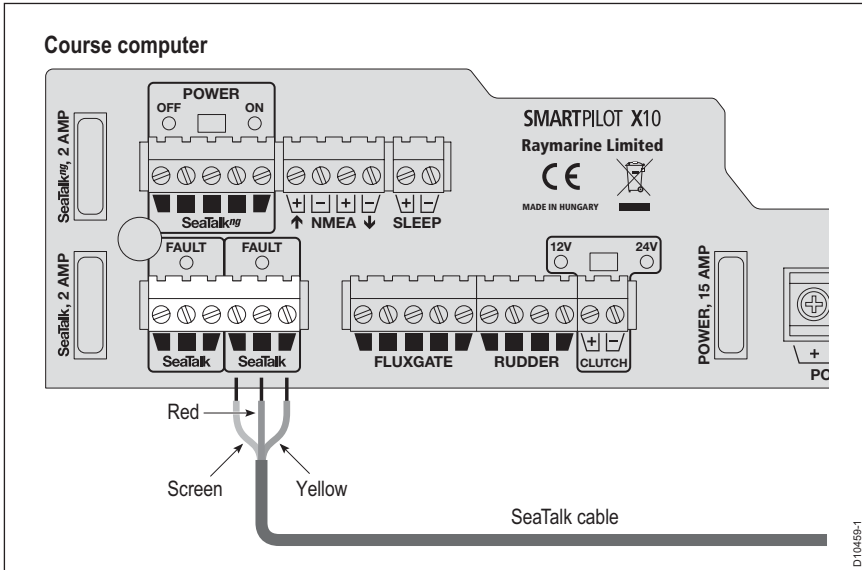

Autopilot controller

- Connect the controller to an existing instrument or a connector block. (For detailed information refer to your autopilot controller installation guide)

Connecting a SeaTalk controller

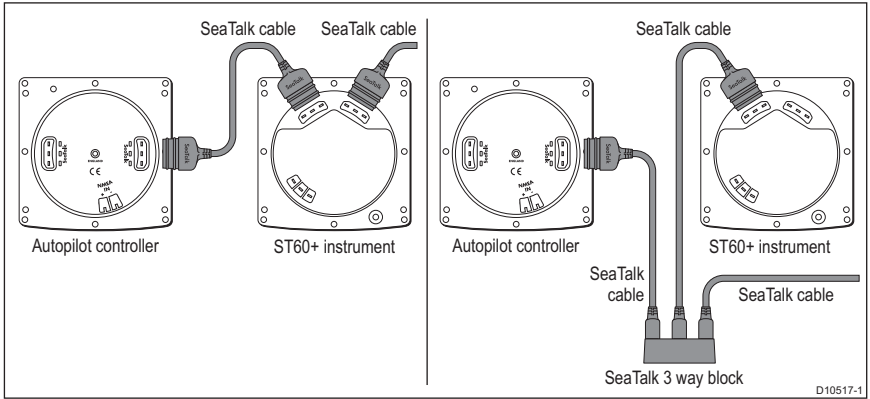

Note: If the controller is to be the primary controller, we recommend a direct connection to the system rather than daisy-chaining the controller to an instrument bus.

To connect NMEA equipment

CAUTION: Connections to other equipment

If you are connecting Raymarine equipment to other equipment using a non-Raymarine cable, you MUST attach an appropriate suppression ferrite to the cable near to the Raymarine unit.

Note: If you are connecting third party equipment, refer to the manufacturer's instructions for installation and cable details. You must not connect more than one piece of equipment to each SPX computer NMEA input.

You may do any of the following:

- Use the SPX computer NMEA input / output
- Use the SeaTalk / NMEA interface (part number: E85001) to convert the NMEA data to SeaTalk data.

Connecting NMEA equipment

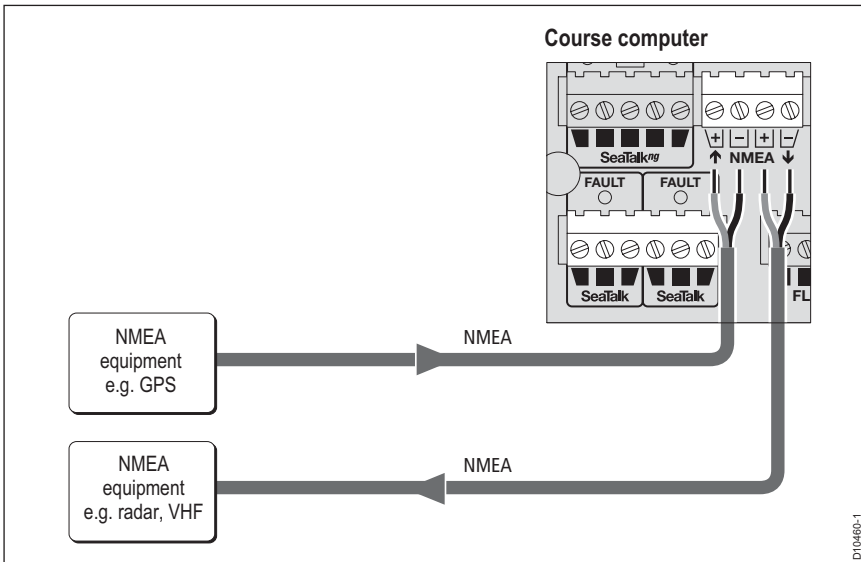

3.8 Compass

CAUTION: Incorrect installation can cause serious performance issues. The most common cause of poor autopilot performance is incorrect compass installation.

CAUTION: Compass subject to interference

The compass is sensitive to magnetic influences and other potential sources of interference including engines and VHF radio waves. To ensure optimum operation it is essential to locate the compass correctly. For detailed instructions refer to the separate installation information supplied with the compass.

To mount the compass

- Fit the fluxgate compass using the installation instructions supplied with the compass, paying particular attention to the compass safe area label.
- If you are using an NMEA compass as the primary compass, connect it to the NMEA input on the SPX SmartPilot.
- If you are using the fluxgate compass included with the SPX SmartPilot, connect the compass' flying lead to the to **FLUXGATE** terminal as shown below.

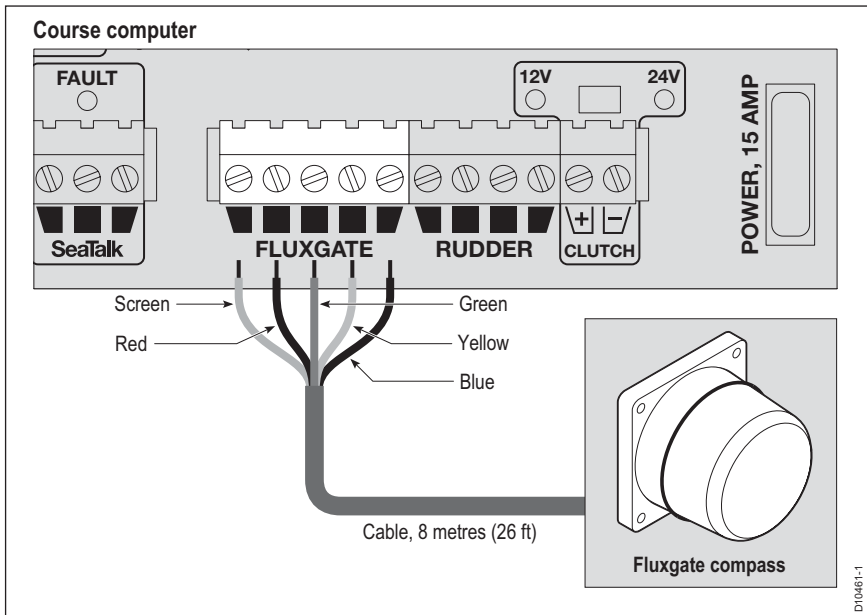

3.9 Rudder reference

- The SPX Solenoid requires a rudder reference to function correctly and is supplied with a unit.
- The SPX 30 is supplied with a rudder reference unit to provide maximum performance.
- The SPX 10 does not require a rudder reference and is not supplied with one. However if the SPX 10 is being used with an extreme performance boat, the addition of a rudder reference may provide enhanced performance.

To mount and connect the rudder reference (if applicable)

- Fit the rudder reference using the instructions supplied with it.
- Route the cable back to the SPX SmartPilot.
- Connect Rudder sensor to **RUDDER** terminal.

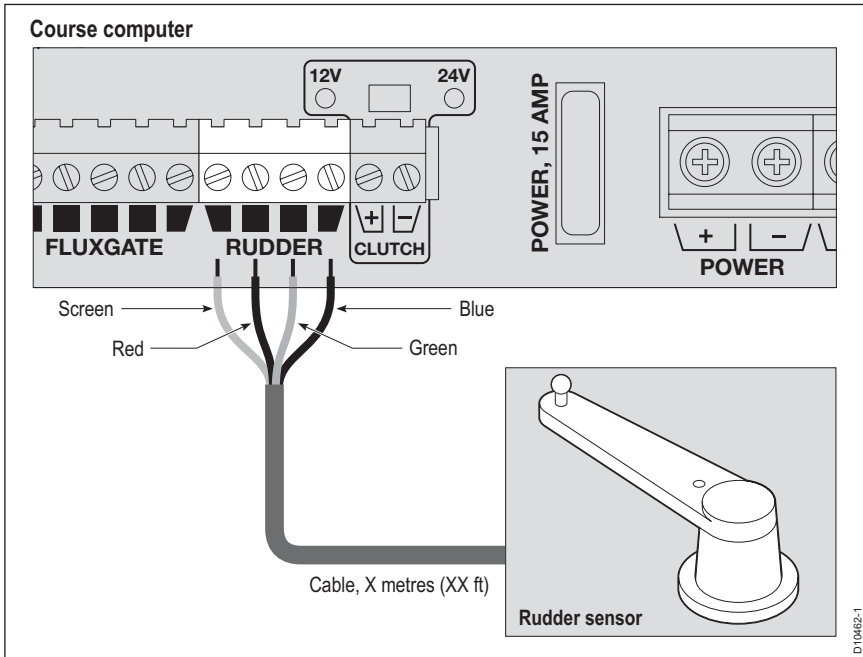

3.10 Sleep switch (optional)

A Sleep switch, which disables the operation of the autopilot (but maintains power to SeaTalk and SeaTalk⁰⁹ bus), may be connected to inputs on the SPX SmartPilot. You need to source an appropriate switch and cabling.

7. Install sleep switch (optional)

CAUTION: Turning the sleep switch to ON will turn the autopilot system OFF in all situations and will override 'AUTO' mode.

- Wire sleep switch.
- Route sleep switch cable to SPX SmartPilot and connect it to the **SLEEP** terminal.

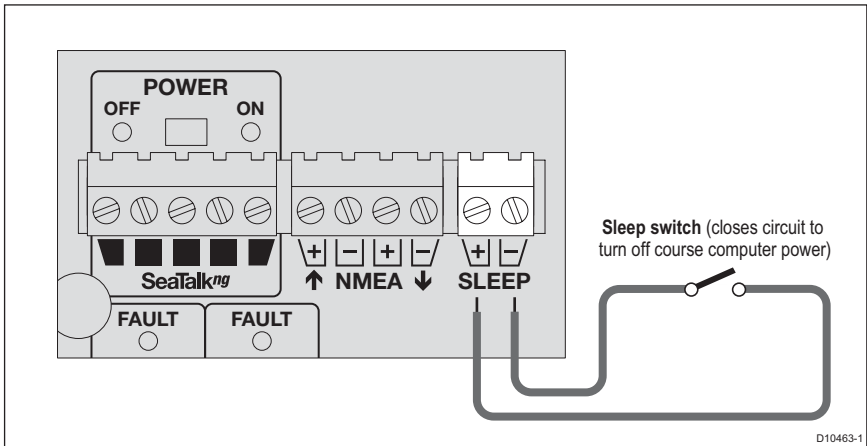

3.11 External alarm (optional)

The SPX SmartPilot sounds all critical alarms from all controllers. On large or noisy boats you can fit a Raymarine external alarm (part number: E26033, connected through E85001 interface box) as a high volume audible repeater.

3.12 Wind vane (sail boats)

The SPX SmartPilot can use wind angle information from a wind vane to maintain a course relative to the wind. You can provide wind angle information to the autopilot system by:

- connecting the wind vane to a transducer pod connected to the SeaTalk⁰⁹ backbone or
- connecting the wind vane to a transducer pod connected to a SeaTalk or NMEA instrument (providing wind angle and speed information). Refer to the installation instructions provided with the wind vane and instrument.

3.13 Test the system

Switch on

- Switch on the main power breaker.

SeaTalk^{ng}

- If you are using an **ST70 autopilot controller** and it does not power up:
 - Switch it on by holding down the Power button for 1 second.
 - If the SPX SmartPilot and autopilot controller are active, the autopilot controller should display a select **LANGUAGE** menu.

Troubleshooting

- If the display is blank, check the fuse/circuit breaker, the SeaTalk^{ng} fuse in the SPX SmartPilot computer and that the SeaTalk^{ng} power switch is set to ON.
- If the display shows the SEATALK^{ng} FAIL or NO DATA alarm message, check the SeaTalk^{ng} connections and terminators.

SeaTalk

- If you are using a **SmartPilot controller** (ST6002, ST7002 or ST8002) and it does not power up:
 - Hold down the Display button for 1 second.
 - If the SPX SmartPilot and autopilot controller are active, the autopilot controller should display a **STANDBY** screen.

Troubleshooting

- If the display is blank, check the fuse/circuit breaker, the SeaTalk fuse in the SPX SmartPilot computer.
- If the display shows the SEATALK^{ng} FAIL or NO DATA alarm message, check the SeaTalk connections and terminators.
- If the **STANDBY** screen does not display a live compass heading or a rudder angle, check the sensor connections.

3.14 Final fix

After connecting any additional components, make sure the system is powered down before finally securing all equipment properly in place.

Secure all cables

To prevent strain on the connector blocks, secure the cables to the SPX SmartPilot computer with cable ties as shown below.

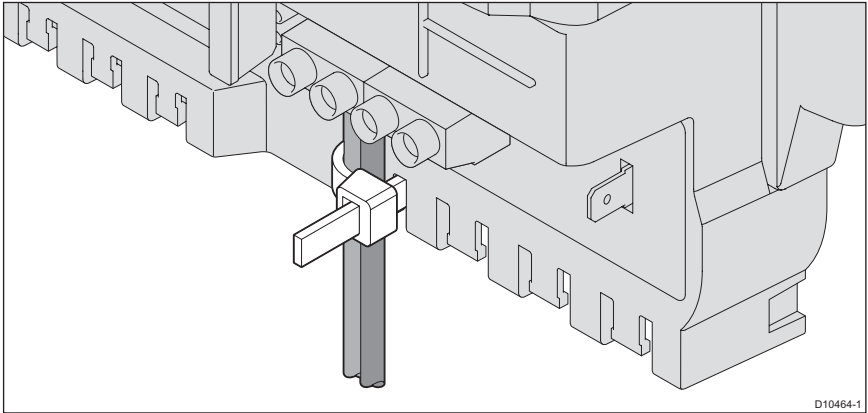

3.15 Commissioning

The autopilot must be commissioned prior to use. For new systems this involves calibrating the system, which is a **safety-critical action**.

Refer to the SPX SmartPilot Commissioning Guide for instructions.

Chapter 4: SPX SmartPilot specifications

SPX SmartPilot computer specifications

Nominal supply voltage X 10 X 30 X SOLENOID	12 or 24 V DC (fuse protected at 15A) 12 or 24 V DC (fuse protected at 40A) 12 or 24 V DC (fuse protected at 15A)
Operating voltage range X 10, X 30, X SOLENOID	10 V to 32 V DC
Power consumption (standby) X 10, X 30, X SOLENOID	300 mA
Gyro	internal GyroPlus fitted onto circuit board as standard
Environmental conditions operating temperature non-operating temperature relative humidity limit water protection	-10°C to 55°C (14°F to 131°F) -20°C to 70°C (-4°F to 158°F) 80% drip resistant when mounted vertically
Storage conditions when packed temperature range relative humidity limit	-5°C to 50°C (23°F to 122°F) 75%
Dimensions X 10, X 30, X SOLENOID	(width, height, depth) 307mm (12.1 in), 195 mm (7.7 in), 70 mm (2.8 in)
Weight X 10 X 30, X SOLENOID	1.1 kg (2.42 lbs) 2.2 kg (4.85 lbs)
Inputs X 10, X30, X SOLENOID	fluxgate compass, rudder position sensor, NMEA 0183 v2.3, SeaTalk, SeaTalk ^{ng} , power, sleep switch
Outputs X 10, X 30 X SOLENOID	NMEA 0183 v2.3, SeaTalk, SeaTalk ^{ng} , drive motor, drive clutch NMEA 0183 v2.3, SeaTalk, SeaTalk ^{ng} , bypass valve, solenoid drive
Raymarine drive compatibility X 10 X 30 X SOLENOID	all Type 1 drives/pumps (excluding CR pumps) (drive voltage must match boat's supply voltage) all Type 1, Type 2 and Type 3 drives / pumps (drive voltage must match boat's supply voltage) CR pumps etc.
Drive motor output X 10 X 30	continuous 10A at supply voltage continuous 30A at supply voltage
Drive clutch output X 10 X 30 X SOLENOID	1.2A at 12 / 24 V selectable 3.0A at 12 / 24 V selectable 2.0A at 12 / 24 V selectable
SeaTalk output X 10 X 30, X SOLENOID	2A at 12 V (fuse protected at 2A) 3A at 12 V (fuse protected at 3A)

SPX SmartPilot computer specifications

SeaTalk ^{ng} output X 10 X 30, X SOLENOID	2A at 12 V (fuse protected at 2A) 3A at 12 V (fuse protected at 3A)
NMEA 0183 v2.3 inputs/out- puts	See <i>NMEA 0183 sentences</i> on <i>page 45</i> for information on NMEA 0183 received/transmitted
NMEA fast heading output X 10, X 30, X SOLENOID	(HDM) 5 Hz 0.1° resolution
Fuses Power Terminals SeaTalk Terminals	Standard automotive blade fuses to protect: X 10: 15A, X 30: 40A, X SOLENOID: 15A X 10: 2A, X 30 and X SOLENOID: 3A
EMC compliance:	Europe 2004/108/EC (EMC) Australia and New Zealand: C-Tick, Compliance Level 2

WARNING: Potential ignition source

Contains a possible source of ignition - NOT protected for use in engine compartments.

Chapter 5: NMEA 0183 sentences

The following NMEA 0183 sentences are supported by the SPX 10, SPX 30 and SPX SOLENOID SmartPilots.

The SPX 10, SPX 30 and SPX Solenoid computers have a single NMEA input/output to receive and transmit information from NMEA equipment.

SmartPilot computer NMEA inputs

NMEA 0183 received	Information extracted
APB	cross track error, bearing to waypoint, waypoint number
BWC BWR	bearing to waypoint, distance to waypoint, waypoint number, time
GGA GLL	latitude/longitude, time
HDG HDM HDT	heading
MWW	apparent wind angle, apparent wind speed
RMA	course over ground (COG), speed over ground (SOG), latitude/longitude, variation
RMB	cross track error, bearing to waypoint, distance to waypoint, waypoint number
RMC	course over ground (COG), speed over ground (SOG), latitude/longitude, time, variation
VHW	speed through water, heading
VTG	course over ground (COG), speed over ground (SOG)
XTE	cross track error
ZDA	time, date

SmartPilot computer NMEA outputs*

NMEA 0183 sent	Information sent
HDG	heading
RSA	rudder angle (only available if rudder reference option fitted)

